

Protech DVR - D1

Hardware Installation Guide

Rev. 1.5

Digital Video Security System
Digital Video Recorder

Protech

*All contents of this document may change without prior notice, and actual product appearance may differ from depicted herein.

INDEX

1. Specification of Protech-D1 Series	3
2. Products and components	5
2-1. DVR Board	5
2-2. Accessories	5
2-3. Optional Accessories	5
3. Board Layout	6
3-1. 48016 D1	6
3-2. I/O Board	6
4. Installation	7
4-1. 48016 D1 Pigtail Type	7
4-2. 48016 D1 Back panel Type	8
5. Accessories	9
5-1. Back panel	9
5-2. Video and Audio Pigtail Cable	10
5-3. Sensor Port	10
5-4. RS232 to RS422/485 Converter	11

Preface

This is a guide book that explains the hardware components and provides a step-by-step installation of DVR board.

For the software explanation, please refer to “Installation and User’s Guide”.

This guide book is applicable to, Between Protech products and 48016 D1 board.

The pictures and the name of the products are subject to change; however, the usage may be similar.

1. Specification of Protech

- **1~16 Camera Inputs / Output**

Up to 16 camera inputs are available on screen for digital handling.

- **1~16 Sensor Inputs**

Up to 16 sensors can be linked to the system

- **1~4 Digital Outputs (Relay Outputs)**

Digital Outputs can be used to activate things like shutters and sirens, and activation can be linked to sensor and motion detection.

- **Sound Recording and Two-Way Communication Capabilities**

Sound can be recorded with video images. Two-way communication is possible between Protech main and Protech Net.

- **Display Features (w/ Multi-Viewing)**

Up to 1, 4, 6, 9, 10 or 16 different camera shots to be displayed onscreen at the same time.

- **PAN/TILT/ZOOM/FOCUS Capabilities**

Each connected camera can be manipulated through the Protech main program as long as each camera supports such capabilities.

- **Auto Rebooting System**

When Protech detects an error or malfunction within the system, it will automatically reboot the system in order to correct it.

- **Motion Detection and Sensor Trigger**

Detection features make it possible to record images only when movement is detected, preserving volume space and maximizing the use of physical storage space.

- **Scheduled Recording**

Scheduling allows the administrator to record images only during designated time periods, if so desired. Every combination of scheduling is available in the Protech program.

- **Data Backup and Auto Backup**

Data can be preserved through various formats (DAT, CD, or DVD) and data from specific cameras and/or time

periods can be specifically isolated for backup as well. Much like scheduled recording, backup of data can be scheduled as well.

- **Digitalized Video Search**

Recorded data features digital playback for each camera simultaneously or one at a time. Playback features include advanced search features and image extracting, which allows portions of existing video to be extracted and saved as a separate file.

- **Network Support (PSTN, TCP/IP, LAN, Modem Protocol Support)**

Protech supports network access, which allows administrators to login to Protech main and remotely access all the features provided locally.

- **Integration with Text data from External Devices**

Data from external devices (POS, Access Control, ATM, etc) can be recorded with DVR video images. Text Search allows to search data from external devices with DVR video image when event occurs. This will raise the level of integrity and security.

Feature	48016D1
Camera Input	1~16 Port (NTSC/PAL)
Sound Input	16 Port
Sensor Input	16 Port
Relay Output	4 Port
Composite Output	1 Port (NTSC/PAL, Split, Switching)
Image Format	MPEG4
Recording Mode	Watch, Normal, Motion Detection, Sensor, Scheduled Recording
Remote Control	Full remote control PSTN, ISDN, ADSL, LAN and TCP/IP
Back-up	DAT, CD, DVD
PAN/TILT/ZOOM/FOCUS	RS-232/422/485 Interface

2. Product and Components

2.1. DVR Board



48016D1

2-2. Accessories



Pigtail Cable



Sound Pigtail Cable



Watchdog Cable

2-3. Optional Accessories



I/O Board



Sensor Port



Sensor & Relay Cable



RS-485 Board



RS-232C Cable



Back panel



Video Cable

3. Board Layout

3-1. 48016 D1

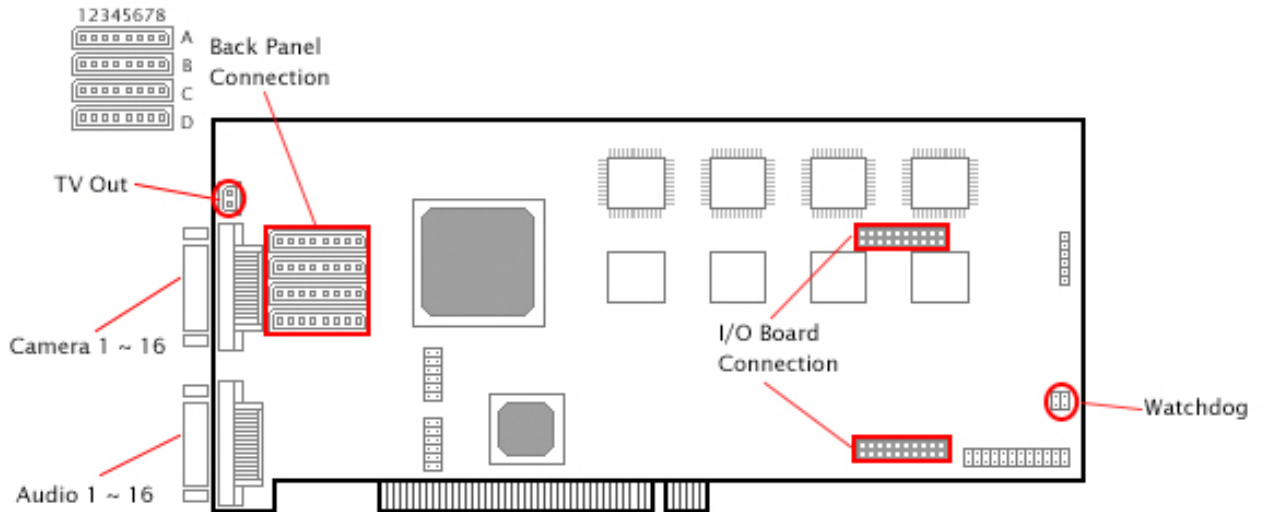

3-2. I/O Board

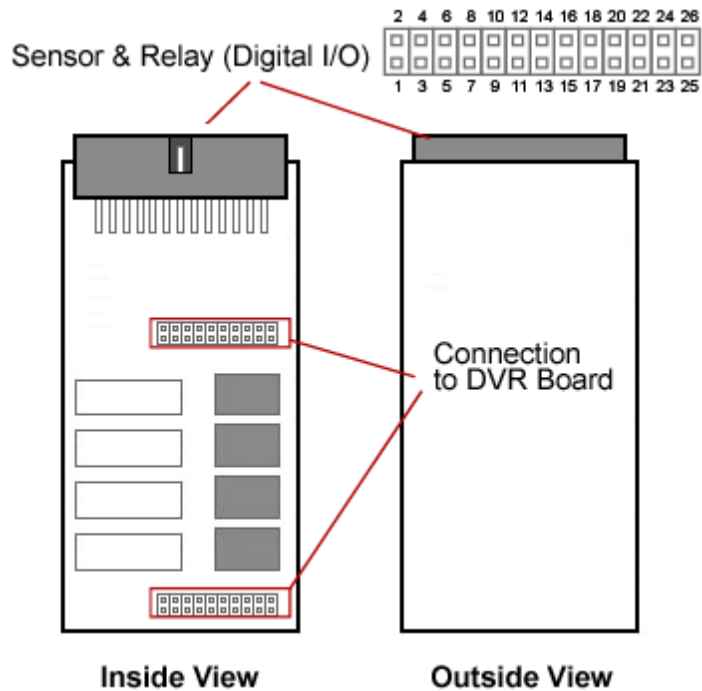

4. Installation

4-1. 48016 D1 Pigtail Type

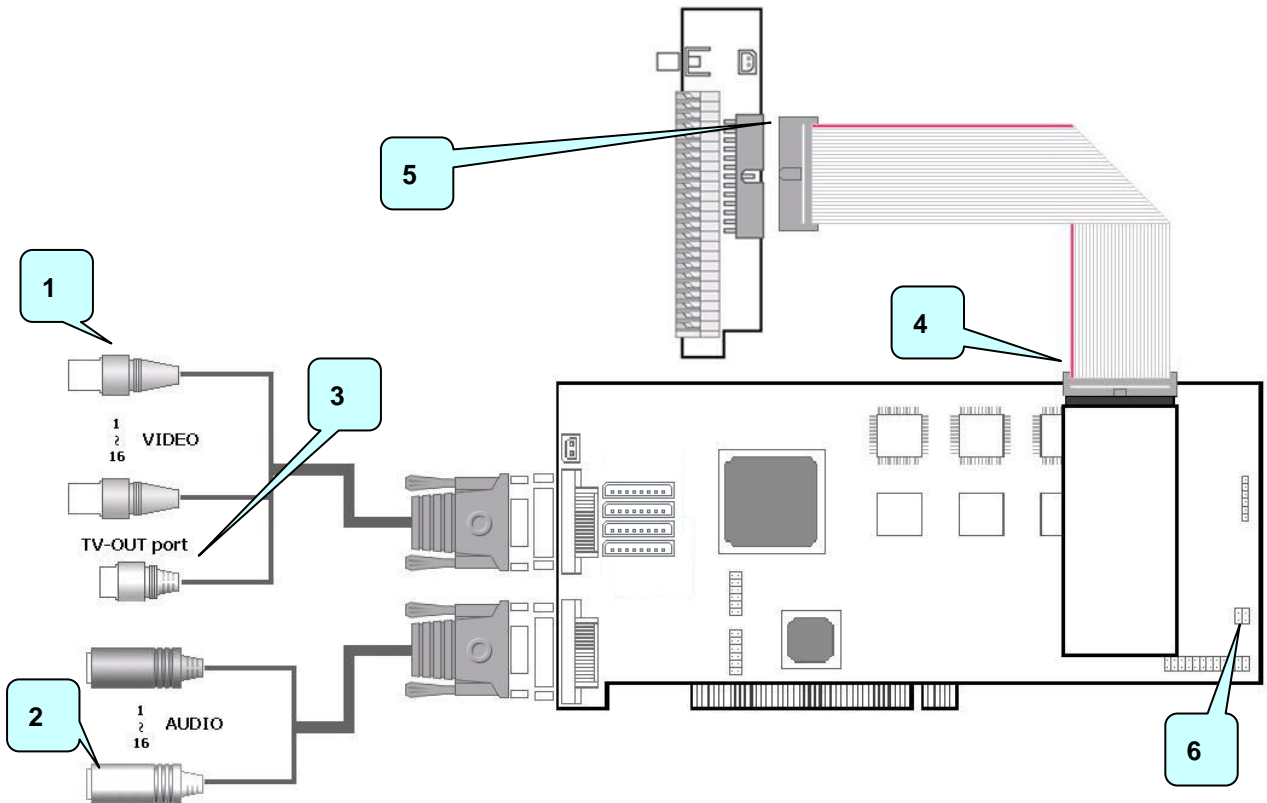

- 1) Connect 1~16 channel video pigtail cable to the top connector.
- 2) Connect 1~16 channel audio pigtail cable to the bottom connector.
- 3) Connect CCTV monitor.
- 4) Connect I/O cable to the sensor port.
- 5) Connect the other side of the I/O cable to the I/O connector.
- 6) Connect watchdog cable. (White cable must go left of the connector)

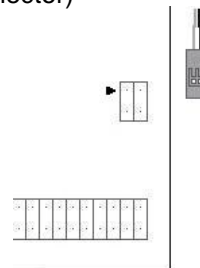

4-2. 48016 D1 Back panel Type

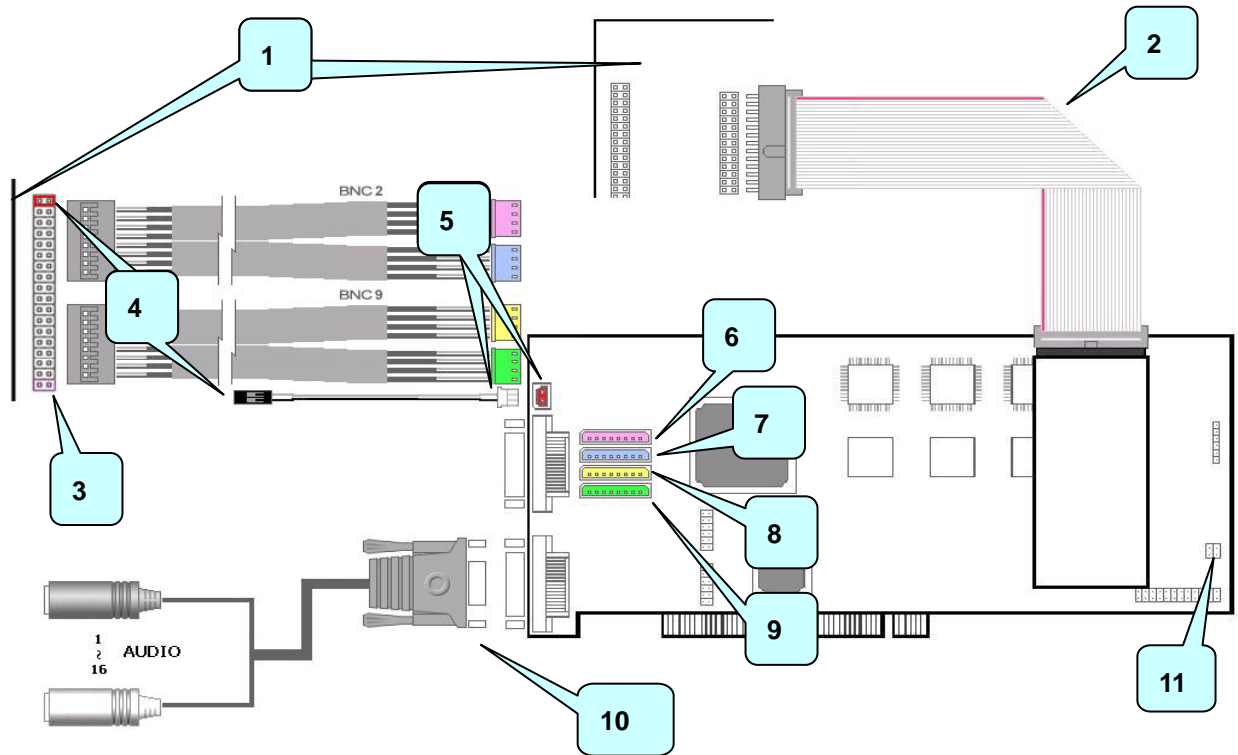

- 1) Back Panel.
- 2) Sensor Cable.
- 3) When connecting video cables to back panel, make sure to leave the bottom pin on the back panel and have white cables facing up.
- 4) Connect TV-Out cable to the top pin on back panel. (make sure to have the white cable facing up)
- 5) Connect the other side of the TV-Out cable to the capture board.
- 6) Connect the video cable with BNC2 label.
- 7) Connect the remaining cable with BNC2 label.
- 8) Connect the video cable with BNC9 label.
- 9) Connect the remaining cable with BNC2 label.
- 10) Connect audio pigtail cable.
- 11) Connect watchdog cable. (White cable must go left of the connector)

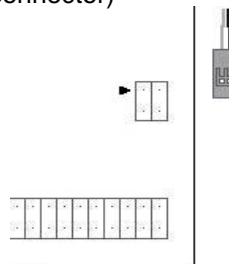

5. Accessories

5-1. Back Panel

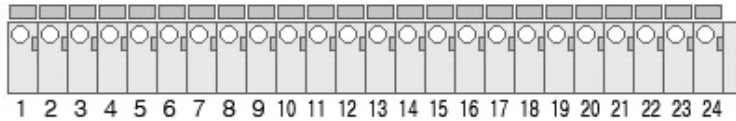

Back Panel Terminal block

Sensor input : 1 ~ 16

Sensor ground : 17, 18

Relay output : 19 ~ 22

Relay ground : 23, 24

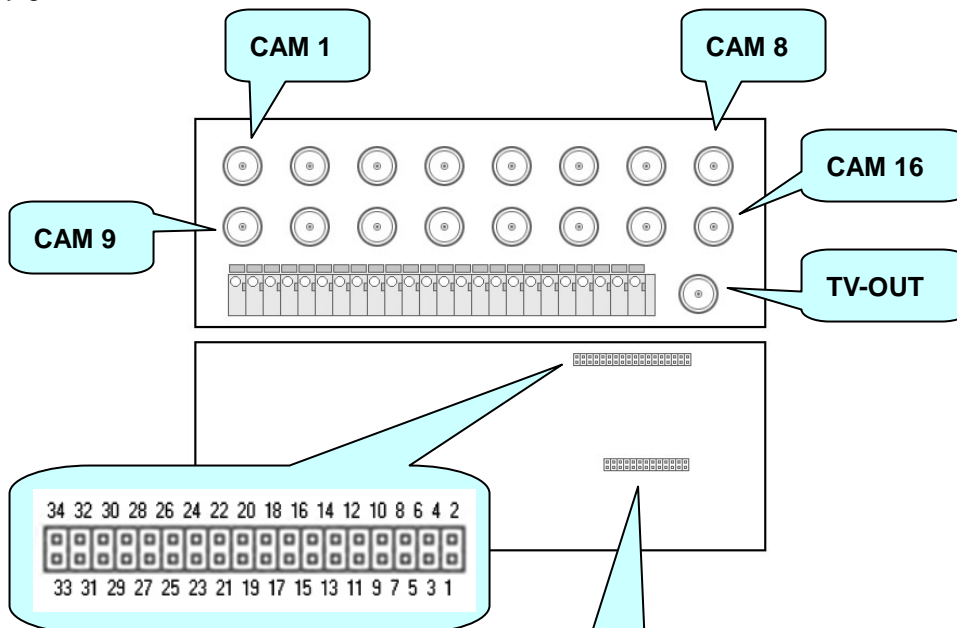

Camera I/O

3, 5, ~ 31, 33 : Camera Ground

4, 6, ~ 32, 34 : Camera Signal

2 : Composite Signal

1 : Composite Ground

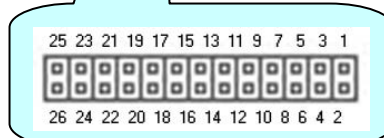

Sensor & Relay I/O

Sensor input : 1, 2 ~ 15, 16

Sensor ground : 17, 18

Relay Output : 19, 20, 21, 22,

Relay ground : 23, 24

5-2. Video and Audio Pigtail Cable

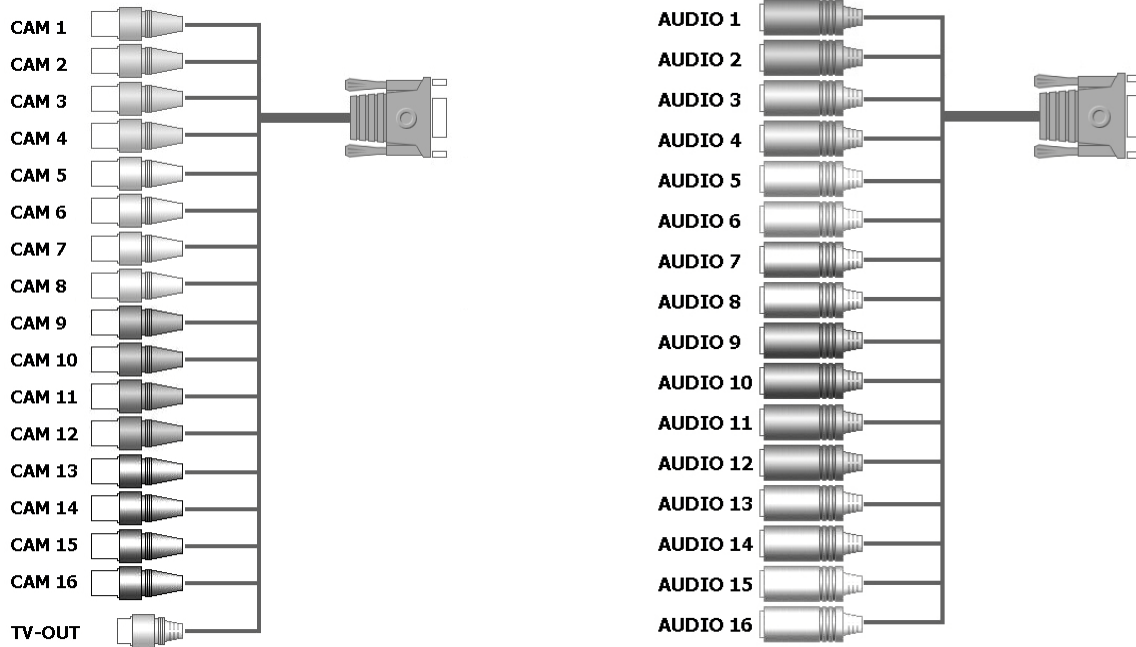

Video Pigtail cable

- 1 ~ 4 : Blue BNC
- 5 ~ 8 : Orange BNC
- 9 ~ 12 : Violet BNC
- 13 ~ 16 : Gray BNC

Audio Pigtail cable

- 1, 9 : Red con
- 2, 10 : Orange con
- 3, 11 : Yellow con
- 4, 12 : Green con
- 5, 13 : Blue con
- 6, 14 : Violet con
- 7, 15 : Gray con
- 8, 16 : White con

5-3. Sensor Port

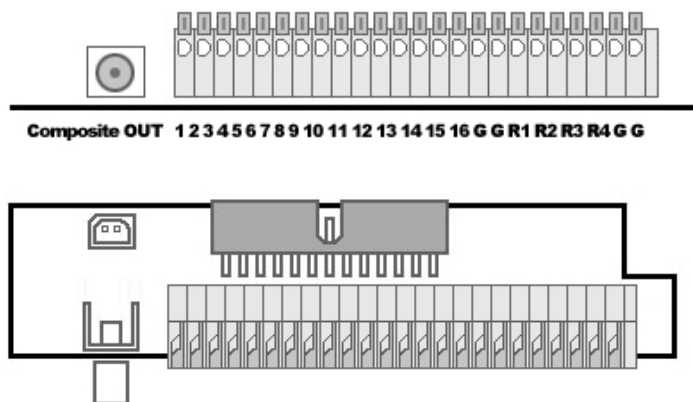

Sensor port pin number

- 1 ~ 16 : Signal input
- G : Ground
- R1, R2, R3, R4 : Relay output

5-4. RS232 to RS422/485 Converter

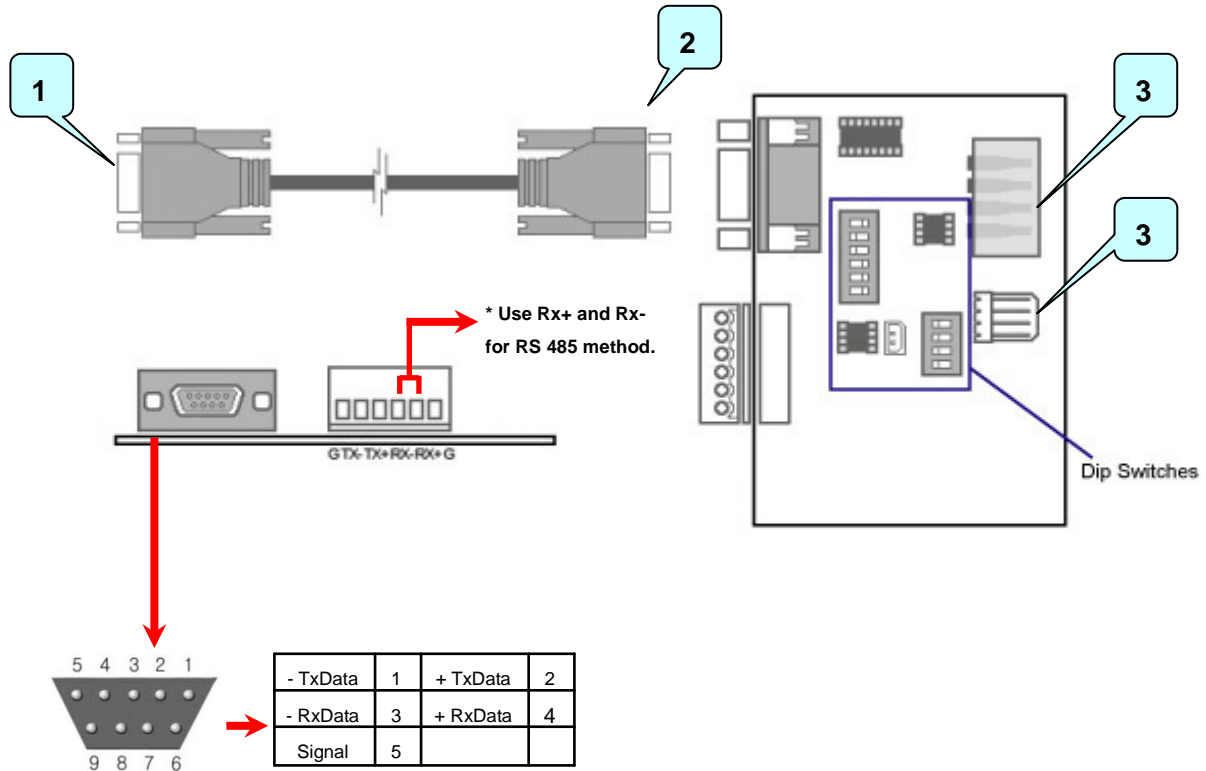

- 1) Connect to system's Com port.
- 2) Connect to PTZ port converter.
- 3) These are power supply sockets. Need to connect only one of them.

Dip Switches

